



SIRIUS safety relay Basic unit Advanced series with time delay 0.05-3 s
 electronic enabling circuits 2 NO instantaneous 2 NO delayed $U_s = 24\text{ V}$
 DC screw terminal

product brand name	SIRIUS
product category	Safety relays
product designation	safety relays
design of the product	Solid-state enabling circuits
General technical data	
protection class IP of the enclosure	IP20
touch protection against electrical shock	finger-safe
insulation voltage rated value	50 V
ambient temperature	
• during storage	-40 ... +80 °C
• during operation	-25 ... +60 °C
air pressure according to SN 31205	90 ... 106 kPa
relative humidity during operation	10 ... 95 %
installation altitude at height above sea level maximum	4 000 m; Derating, see Product Notification 109792701
vibration resistance according to IEC 60068-2-6	5 ... 500 Hz: 0.75 mm
shock resistance	10g / 11 ms
surge voltage resistance rated value	800 V
EMC emitted interference	IEC 60947-5-1, Class A
installation environment regarding EMC	This product is suitable for Class A environments only. In household environments, this device can cause unwanted radio interference. The user is required to implement appropriate measures in this case.
overvoltage category	3
degree of pollution	3
reference code according to IEC 81346-2	F
power loss [W] maximum	2 W
number of sensor inputs 1-channel or 2-channel	1
design of the cascading	yes
type of the safety-related wiring of the inputs	single-channel and two-channel
product feature cross-circuit-proof	Yes
Safety Integrity Level (SIL)	
• according to IEC 62061	3
• according to IEC 61508	3
• for delayed release circuit according to IEC 61508	SIL3
performance level (PL)	
• according to ISO 13849-1	e
• for delayed release circuit according to EN ISO 13849-1	e
category according to EN ISO 13849-1	4
Safe failure fraction (SFF)	99 %
PFHD with high demand rate according to EN 62061	1.5E-9 1/h
PFDAvg with low demand rate according to IEC 61508	7E-6
T1 value for proof test interval or service life	20 y

according to IEC 61508	1
hardware fault tolerance according to IEC 61508	Type B
safety device type according to IEC 61508-2	

Inputs/ Outputs

number of outputs as contact-affected switching element	
<ul style="list-style-type: none"> as NO contact <ul style="list-style-type: none"> safety-related instantaneous contact safety-related delayed switching 	0 0
number of outputs as contact-less semiconductor switching element	
<ul style="list-style-type: none"> safety-related <ul style="list-style-type: none"> delayed switching instantaneous contact 	2 2
stop category according to EN 60204-1	0 / 1
design of input	
<ul style="list-style-type: none"> cascading input/functional switching feedback input start input 	Yes Yes Yes
type of electrical connection plug-in socket	No
operating frequency maximum	2 000 1/h
switching capacity current	
<ul style="list-style-type: none"> of semiconductor outputs at DC-13 at 24 V 	2 A
design of the fuse link for short-circuit protection of the NO contacts of the relay outputs required	not required
wire length	
<ul style="list-style-type: none"> with Cu 1.5 mm² and 150 nF/km per sensor circuit maximum 	4 000 m
make time with automatic start	
<ul style="list-style-type: none"> at DC maximum 	85 ms
make time with automatic start after power failure	
<ul style="list-style-type: none"> typical maximum 	6 500 ms 6 500 ms
make time with monitored start	
<ul style="list-style-type: none"> maximum 	85 ms
backslide delay time after opening of the safety circuits typical	40 ms
adjustable OFF-delay time after opening of the safety circuits	0.05 ... 3
recovery time after opening of the safety circuits typical	30 ms
recovery time after power failure typical	6.5 s
pulse duration	
<ul style="list-style-type: none"> of the sensor input minimum of the ON pushbutton input minimum 	60 ms 0.15 s

Control circuit/ Control

type of voltage of the control supply voltage	DC
control supply voltage	
<ul style="list-style-type: none"> at DC <ul style="list-style-type: none"> rated value 	24 V
operating range factor control supply voltage rated value of magnet coil	
<ul style="list-style-type: none"> at DC 	0.8 ... 1.2

Installation/ mounting/ dimensions

mounting position	any
required spacing for grounded parts at the side	5 mm
fastening method	screw and snap-on mounting
width	22.5 mm
height	100 mm
depth	121.6 mm

Connections/ Terminals

type of electrical connection	screw-type terminals
type of connectable conductor cross-sections	
<ul style="list-style-type: none"> solid 	1x (0.5 ... 2.5 mm ²), 2x (1.0 ... 1.5 mm ²)

- finely stranded
— with core end processing

1x (0.5 ... 2.5 mm²), 2x (0.5 ... 1.0 mm²)

type of connectable conductor cross-sections at AWG cables

- solid
- stranded

1x (20 ... 14), 2x (18 ... 16)
1x (20 ... 16), 2x (20 ... 16)

Product Function

product function parameterizable

sensor floating / sensor non-floating, monitored start-up / automatic start, 1-channel / 2-channel sensor connection, cross-circuit detection, startup testing, antivalent sensors, 2-hand switches, time delay

suitability for operation device connector 3ZY12

Yes

suitability for interaction press control

Yes

suitability for use

- safety switch
- monitoring of floating sensors
- monitoring of non-floating sensors
- magnetically operated switch monitoring
- safety-related circuits

Yes
Yes
Yes
Yes
Yes

Certificates/ approvals

General Product Approval

EMC



[Confirmation](#)



Functional Safety/Safety of Machinery

Declaration of Conformity

Test Certificates

Marine / Shipping

[Type Examination Certificate](#)



EG-Konf.

[Type Test Certificates/Test Report](#)



DNV



LRS



RINA

Marine / Shipping

other

Railway



[Confirmation](#)

[Confirmation](#)

Further information

Information- and Downloadcenter (Catalogs, Brochures,...)

<https://www.siemens.com/ic10>

Industry Mall (Online ordering system)

<https://mall.industry.siemens.com/mall/en/en/Catalog/product?mlfb=3SK1122-1CB41>

Cax online generator

<http://support.automation.siemens.com/WW/CAXorder/default.aspx?lang=en&mlfb=3SK1122-1CB41>

Service&Support (Manuals, Certificates, Characteristics, FAQs,...)

<https://support.industry.siemens.com/cs/ww/en/ps/3SK1122-1CB41>

Image database (product images, 2D dimension drawings, 3D models, device circuit diagrams, EPLAN macros, ...)

http://www.automation.siemens.com/bilddb/cax_de.aspx?mlfb=3SK1122-1CB41&lang=en

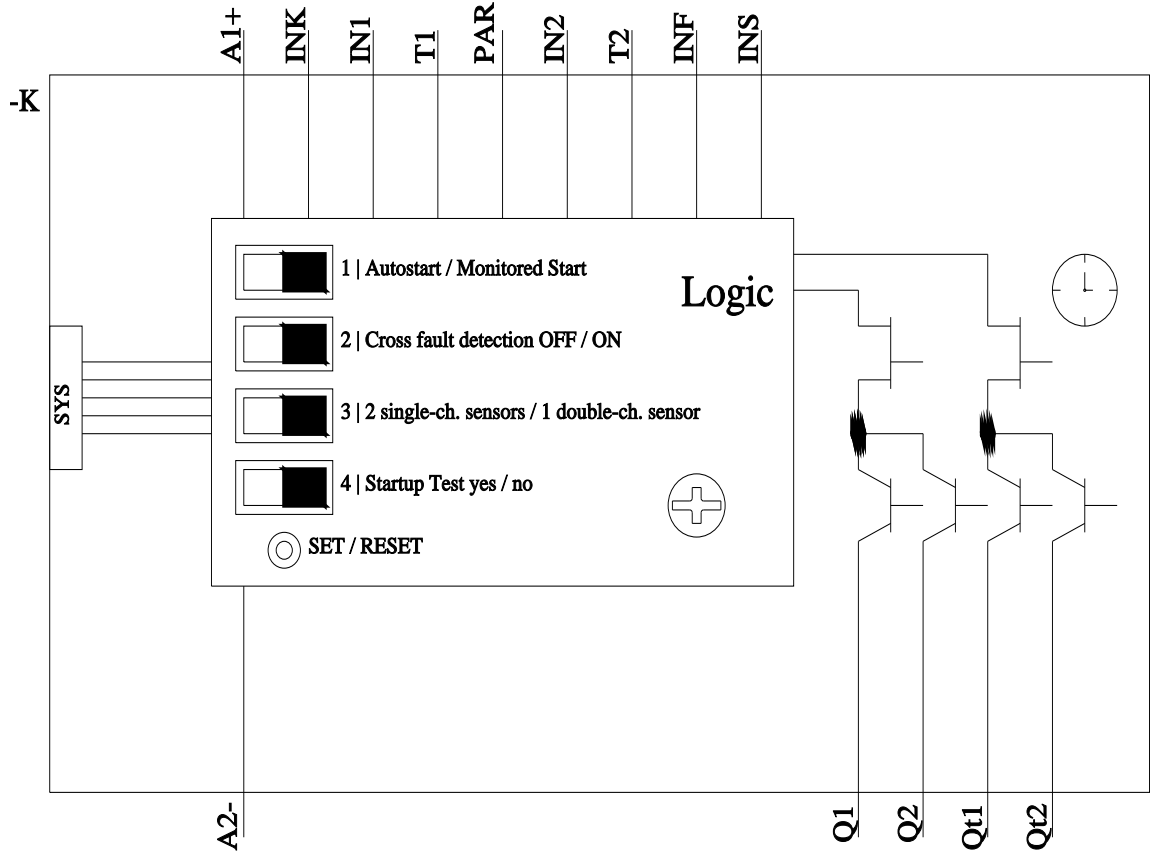
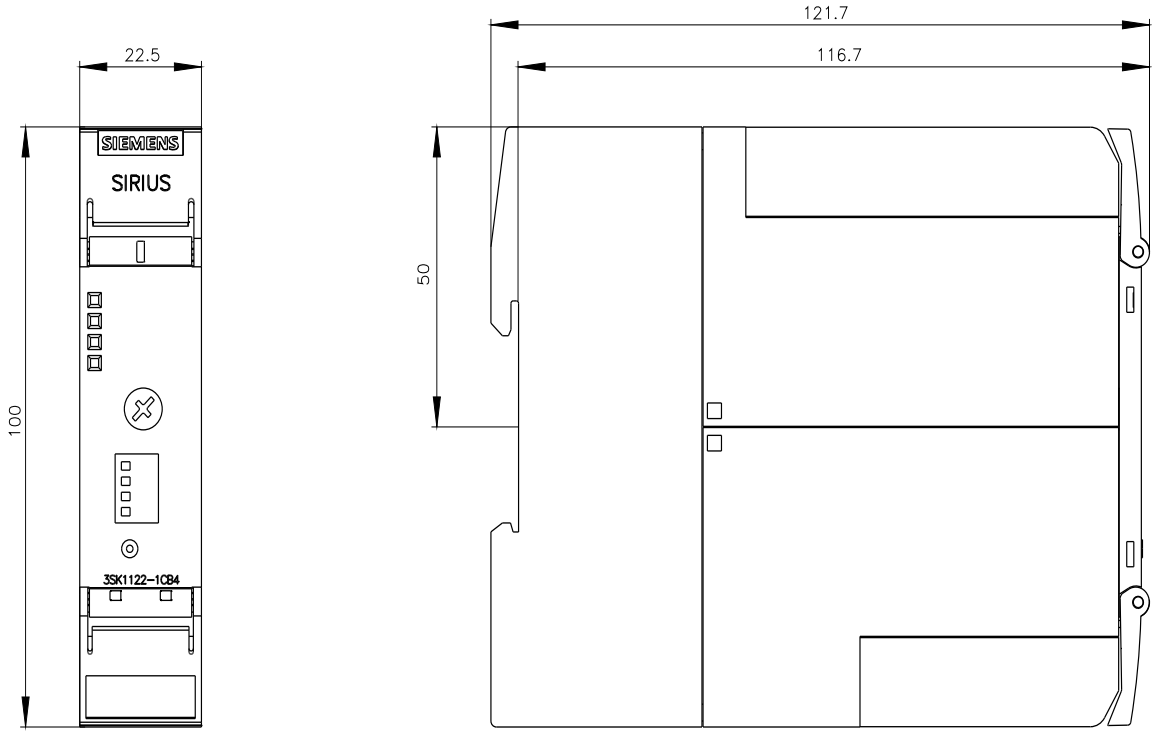

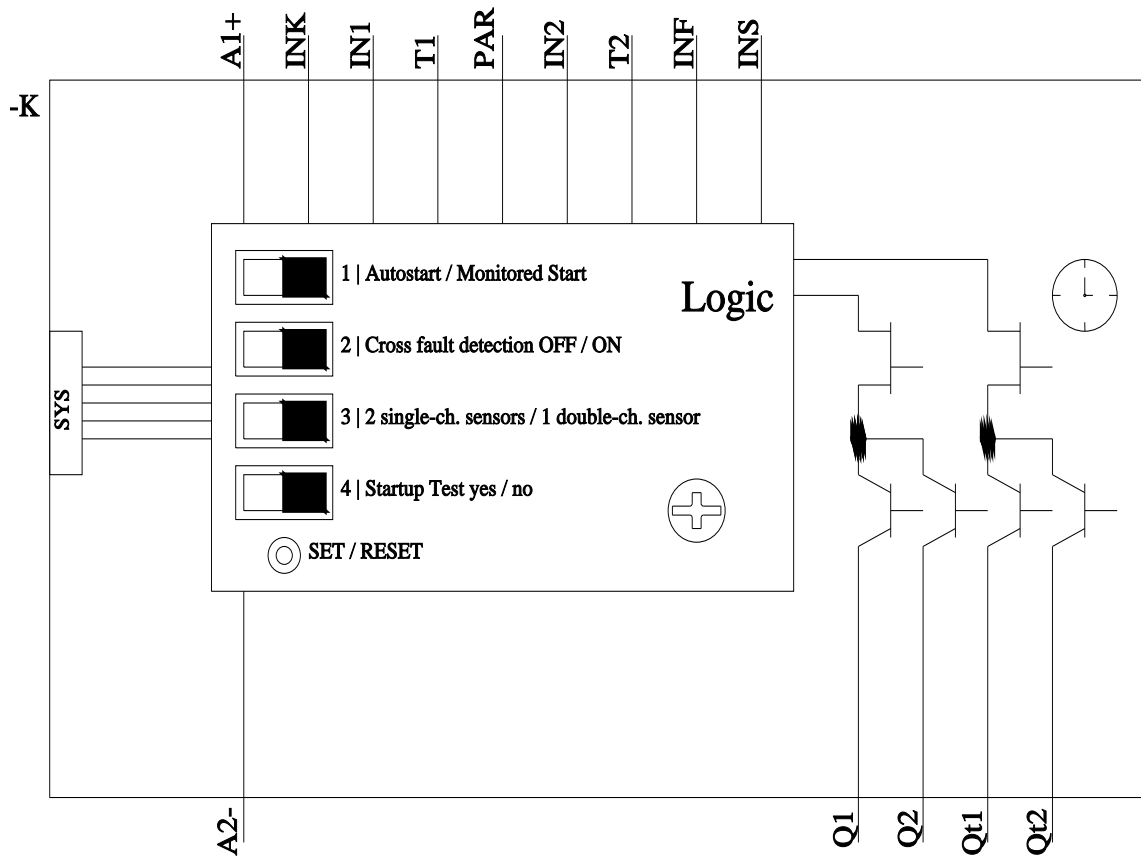

last modified:

9/29/2022 