



**Contactor, 7,5kW/400V, AC-operated**

**Part no.**

**DILM15-10(230V50HZ,240V60HZ)**

**Article no.**

**290058**



## Delivery programme

Product range			Contactors
Application			Contactors for Motors
Subrange			Contactors up to 170 A, 3 pole
Connection technique			Screw terminals
Pole			3 pole
Rated operational current			
AC-3			
380 V 400 V	$I_e$	A	15.5
AC-1			
Conventional free air thermal current, 3 pole, 50 - 60 Hz			
Open			
at 60 °C	$I_{th} = I_e$	A	20
Max. rating for three-phase motors, 50 - 60 Hz			
AC-3			
220 V 230 V	P	kW	4
380 V 400 V	P	kW	7.5
660 V 690 V	P	kW	7
AC-4			
220 V 230 V	P	kW	2
380 V 400 V	P	kW	3
660 V 690 V	P	kW	4.4
Contacts			
N/O = Normally open			1 N/O
Contact sequence			
<b>Instructions</b>			integrated suppressor circuit in actuating electronics with mirror contact. Contacts to EN 50012.
Can be combined with auxiliary contact			DILM32-XHI.. DILA-XHI(V)..
Voltage AC/DC			AC operation

## Approbatoren

Product Standards  
UL File No.  
UL CCN  
CSA File No.  
CSA Class No.  
NA Certification  
Specially designed for NA

IEC/EN 60947-4-1; UL 508; CSA-C22.2 No. 14-05; CE marking  
E29096  
NLDX  
012528  
2411-03, 3211-04  
UL Listed, CSA certified  
No

## General

Standards			IEC/EN 60947, VDE 0660, UL, CSA
Lifespan, mechanical			
AC operated	Operations	$x 10^6$	10
DC operated	Operations	$x 10^6$	10
Operating frequency, mechanical			
AC operated	Operations/h		5000
DC operated	Operations/h		5000

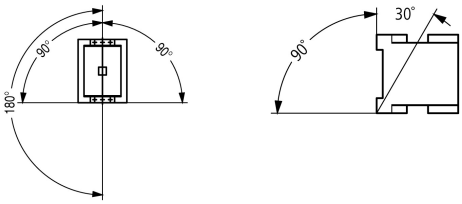
Climatic proofing			Damp heat, constant to IEC 60068-2-78 Damp heat, cyclic to IEC 60068-2-30
Ambient temperature		°C	
Open		°C	- 25 - 60
Enclosed		°C	- 25 - 40
Storage		°C	- 40 - 80
Mounting position, AC- and DC operated			
Mechanical shock resistance (IEC/EN 60068-2-27)			
Half-sinusoidal shock, 10 ms			
Main contacts			
N/O contact		g	10
Auxiliary contacts			
N/O contact		g	7
N/C contact		g	5
Mechanical shock resistance (IEC/EN 60068-2-27) when tabletop-mounted			
Half-sinusoidal shock, 10 ms			
Main contacts			
N/O contact		g	5.7
Auxiliary contacts			
N/O contact		g	3.4
N/C contact		g	3.4
Protection type			IP00
Protection against direct contact when actuated from front (EN 90274)			Finger- and back-of-hand proof
Weight			
AC operated		kg	0.23
DC operated		kg	0.28
Terminal capacity main cable			
Solid		mm <sup>2</sup>	1 x (0.75 - 4) 2 x (0.75 - 2.5)
Flexible with ferrule		mm <sup>2</sup>	1 x (0.75 - 2.5) 2 x (0.75 - 2.5)
			Also without ferrule.
Solid or stranded		AWG	18 - 10
Main cable connection screw/bolt			M3.5
Tightening torque		Nm	1.2
Terminal capacity control circuit cables			
Solid		mm <sup>2</sup>	1 x (0.75 - 4) 2 x (0.75 - 2.5)
Flexible with ferrule		mm <sup>2</sup>	1 x (0.75 - 2.5) 2 x (0.75 - 2.5)
Solid or stranded		AWG	18 - 14
Control circuit cable connection screw/bolt			M3.5
Tightening torque		Nm	1.2
Tool			
Main cable			
Pozidriv screwdriver		Size	2
Standard screwdriver		mm	0.8 x 5.5 1 x 6
Control circuit cables			
Pozidriv screwdriver		Size	2
Standard screwdriver		mm	0.8 x 5.5 1 x 6
Terminal capacity main cable			

Solid		mm <sup>2</sup>	1 x (0.75 - 2.5) 2 x (0.75 - 2.5)
flexible		mm <sup>2</sup>	1 x (0.75 - 2.5) 2 x (0.75 - 2.5)
flexible with ferrules		mm <sup>2</sup>	1 x (0.75 - 1.5) 2 x (0.75 - 1.5)
Solid or stranded		AWG	18 - 14
Terminal capacity control circuit cables			
Solid		mm <sup>2</sup>	1 x (0.75 - 2.5) 2 x (0.75 - 2.5)
Flexible		mm <sup>2</sup>	1 x (0.75 - 2.5) 2 x (0.75 - 2.5)
Flexible with ferrule		mm <sup>2</sup>	1 x (0.75 - 1.5) 2 x (0.75 - 1.5)
Solid or stranded		AWG	18 - 14
Tool			
Stripping length		mm	10
Screwdriver blade width		mm	3.5

## Main conducting paths

Rated impulse withstand voltage	$U_{imp}$	V AC	8000
Overvoltage category/pollution degree			III/3
Rated insulation voltage	$U_i$	V AC	690
Rated operational voltage	$U_e$	V AC	690
Safe isolation to VDE 0106 Part 101 and Part 101/A1			
between coil and contacts		V AC	400
between the contacts		V AC	400
Making capacity (p.f. to IEC/EN 60947)			
	$U_p$ to 690 V	A	155
Breaking capacity			
220/230 V		A	124
380/400 V		A	124
500 V		A	100
660/690 V		A	70
Short-circuit rating			
Short-circuit protection maximum fuse			
Type "2" coordination			
400 V	gG/gL 500 V	A	20
690 V	gG/gL 690 V	A	20
Type "1" coordination			
400 V	gG/gL 500 V	A	63
690 V	gG/gL 690 V	A	50

## AC

AC-1 duty			
Conventional free air thermal current, 3 pole, 50 - 60 Hz			
Open			
at 40 °C	$I_{th} = I_e$	A	22
at 50 °C	$I_{th} = I_e$	A	21
at 55 °C	$I_{th} = I_e$	A	21
at 60 °C	$I_{th} = I_e$	A	20
enclosed	$I_{th}$	A	18
Conventional free air thermal current, 1 pole			
open	$I_{th}$	A	50
enclosed	$I_{th}$	A	45
AC-3 duty			
Rated operational current AC-3 open, 50 - 60 Hz, 3 pole			
220/230 V	$I_e$	A	15.5
240 V	$I_e$	A	15.5

380/400 V	$I_e$	A	15.5
415 V	$I_e$	A	15.5
440V	$I_e$	A	15.5
500 V	$I_e$	A	12.5
660/690 V	$I_e$	A	9
Motor rating	P	kWh	
220/230 V	P	kW	4
240V	P	kW	4.6
380/400 V	P	kW	7.5
415 V	P	kW	8
440 V	P	kW	8.4
500 V	P	kW	7.5
660/690 V	P	kW	7
AC-4 duty			
Rated operational current AC-4 open, 50 - 60 Hz, 3 pole	$I_e$		
220/230 V	$I_e$	A	7
240 V	$I_e$	A	7
380/400 V	$I_e$	A	7
415 V	$I_e$	A	7
440 V	$I_e$	A	7
500 V	$I_e$	A	6
660/690 V	$I_e$	A	5
Motor rating	P	kWh	
220/230 V	P	kW	2
240 V	P	kW	2.2
380/400 V	P	kW	3
415 V	P	kW	3.4
440 V	P	kW	3.6
500 V	P	kW	3.5
660/690 V	P	kW	4.4

## DC

Rated operational current, open			
DC-1 operation			
60 V	$I_e$	A	20
110 V	$I_e$	A	20
220 V	$I_e$	A	15
440 V	$I_e$	A	1.3
DC-3 operation			
60 V	$I_e$	A	20
110 V	$I_e$	A	20
220 V	$I_e$	A	1.5
440 V	$I_e$	A	0.2
DC-5 operation			
60 V	$I_e$	A	20
110 V	$I_e$	A	20
220 V	$I_e$	A	1.5
440 V	$I_e$	A	0.2

## Current heat loss (3 pole)

Current heat loss at $I_{th}$		W	3
Current heat loss at $I_e$ to AC-3/400 V		W	1.8
Impedance per pole		mΩ	2.5

## Magnet systems

Voltage tolerance		x $U_c$	
-------------------	--	---------	--

AC operated	Pick-up	$x U_c$	0.8 - 1.1
Drop-out voltage AC operated	Drop-out	$x U_c$	0.3 - 0.6
DC operated	Pick-up	$x U_c$	0.7 - 1.2
Notes			at least smoothed two-phase bridge rectifier or three-phase rectifier
DC operated	Drop-out	$x U_c$	0.15 - 0.6
Power consumption of the coil in a cold state and $1.0 \times U_c$			
50 Hz	Pick-up	VA	24
50 Hz	Sealing	VA	3.4
50 Hz	Sealing	W	1.2
60 Hz	Pick-up	VA	30
60 Hz	Sealing	VA	4.4
60 Hz	Sealing	W	1.4
50/60 Hz	Pick-up	VA	27 25
50/60 Hz	Sealing	VA	4.2 3.3
50/60 Hz	Sealing	W	1.4 1.2
DC operated	Pick-up	W	4.5
DC operated	Sealing	W	4.5
Duty factor		% DF	100
Switching times at 100 % $U_c$ (approximate values)			
Main contacts			
AC operated			
Closing delay		ms	15 - 21
Opening delay		ms	9 - 18
DC operated		ms	
Closing delay		ms	31
Opening delay		ms	12
Arcing time		ms	10
Lifespan, mechanical; Coil 50/60 Hz	at 50 Hz		Mechanical lifespan at 50 Hz approx. 30% lower than under "Technical data, general"

### Electromagnetic compatibility (EMC)

Emitted interference			to EN 60947-1
Interference immunity			to EN 60947-1

### Technische Daten nach ETIM 4.0

Number of main contacts as N/Os			3
Rated operation current $I_e$ at AC-1, 400 V			14
Connection type main circuit			Screw connection
Rated control voltage $U_s$ at AC 60HZ		V	240
Number of auxiliary contacts as N/Os			1
Rated control voltage $U_s$ at AC 50HZ		V	230
Number of auxiliary contacts as N/Cs			0
Suitable for rail-mounting			No
Rated control voltage $U_s$ at DC		V	0
Voltage type for actuation			AC
Rated operation current $I_e$ at AC-3, 400 V		A	15.5
Number of N/Cs as main contact			0
Motor rating at AC-3, 400 V		kWh	7.5

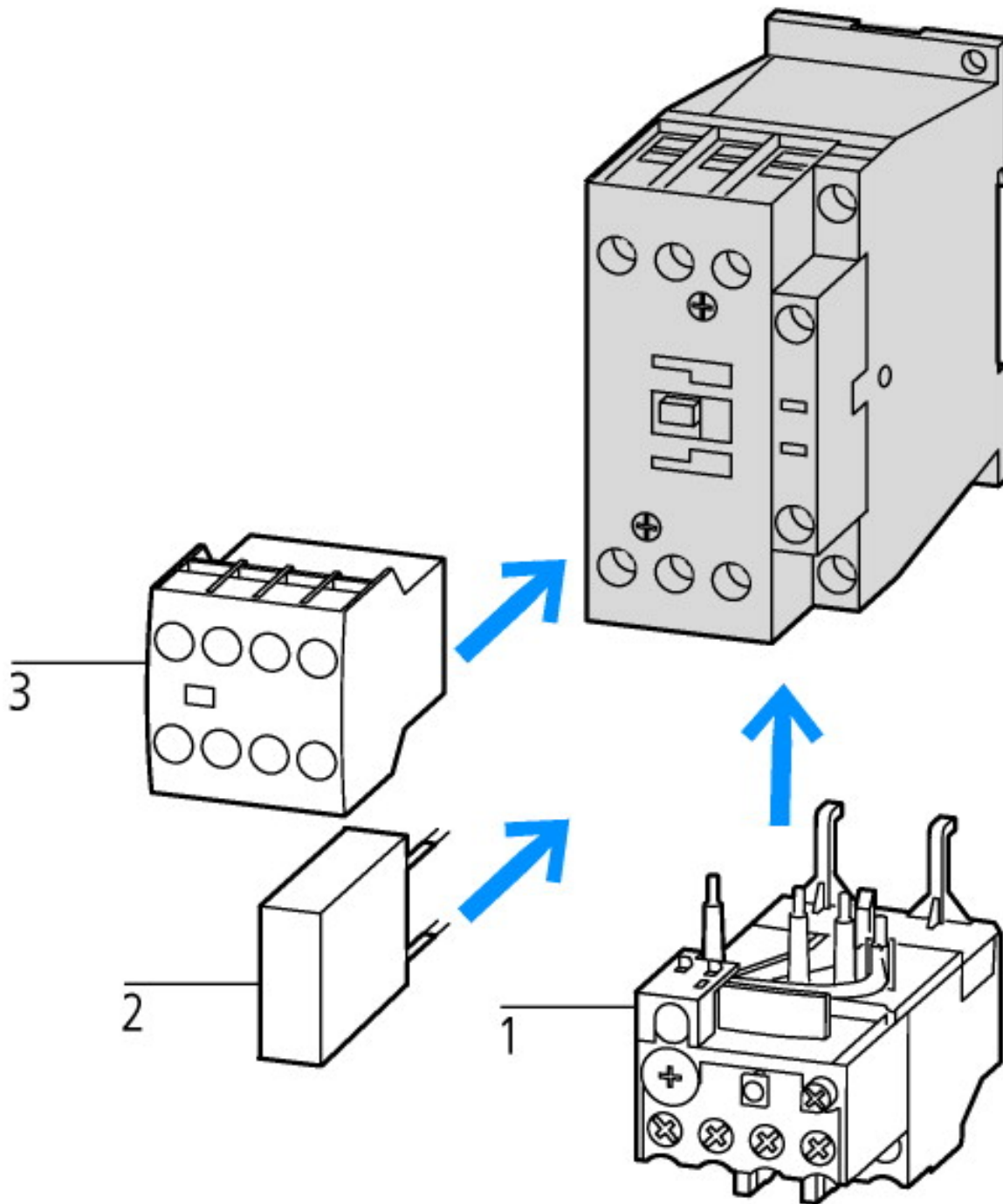

- 1: Overload relay
- 2: Suppressor
- 3: Auxiliary contact modules

Projektieren

### CAD-Daten

Product standards CAD data:

<http://eaton-moeller.partcommunity.com>

### Dimensions

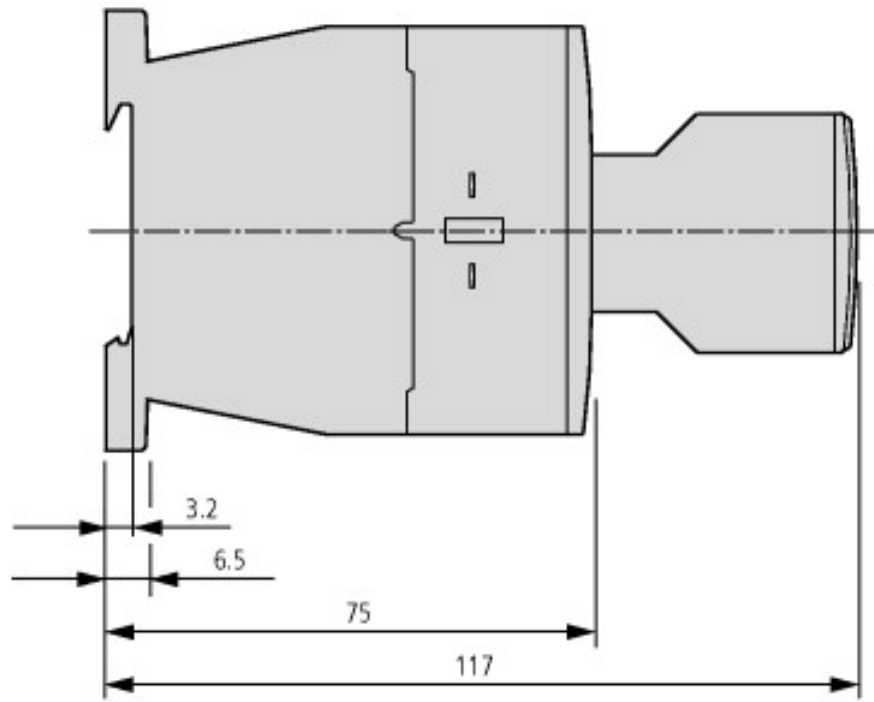
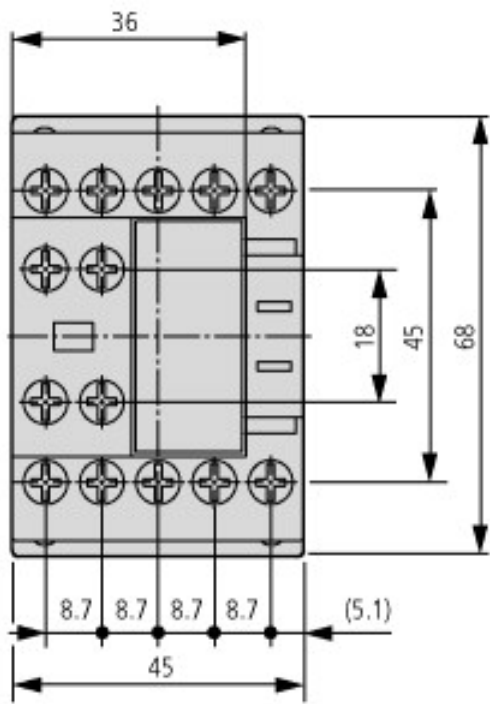

Contacteur with auxiliary contact module

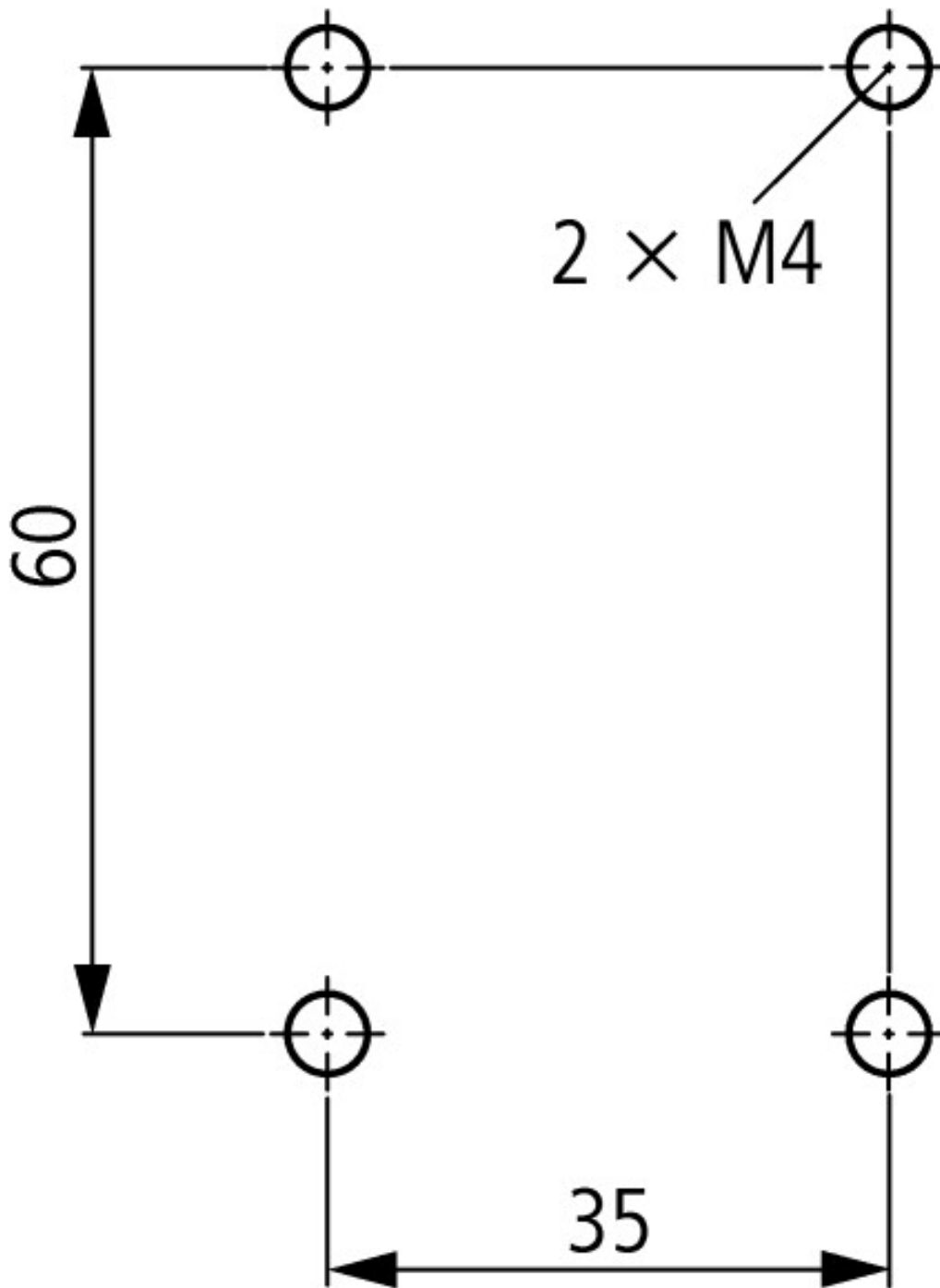

#### Additional product information (links)

IL03407013Z (AWA2100-2126) contactors

[ftp://ftp.moeller.net/DOCUMENTATION/AWA\\_INSTRUCTIONS/IL03407013Z2010\\_10.pdf](ftp://ftp.moeller.net/DOCUMENTATION/AWA_INSTRUCTIONS/IL03407013Z2010_10.pdf)