

# LV- 12- 24UC - Plug-in module



2833712

<https://www.phoenixcontact.com/pc/products/2833712>

Please be informed that the data shown in this PDF document is generated from our online catalog. Please find the complete data in the user documentation. Our general terms of use for downloads are valid.



Plug-in module, for mounting on PR1 and PR2, with varistor and yellow LED, input voltage: 12 ...  
24 V AC/ DC  $\pm 20$  %

## Your advantages

- Mechanical coding to protect against mismatching
- Attenuation of reverse voltage induced in coil

## Commercial data

Item number	2833712
Packing unit	10 pc
Minimum order quantity	1 pc
Product key	CKF346
Catalog page	Page 392 (C-7-2015)
GTIN	4017918933906
Weight per piece (including packing)	2.93 g
Weight per piece (excluding packing)	2.78 g
Customs tariff number	85366990
Country of origin	CN

# LV- 12- 24UC - Plug-in module

2833712

<https://www.phoenixcontact.com/pc/products/2833712>



## Technical data

### Product properties

Product type	Plug-in module
Product family	ESSENTIAL edition

### Electrical properties

Nominal voltage $U_N$	12 V AC/DC ... 24 V AC/DC
-----------------------	---------------------------

### Input data

Input voltage range	12 V AC/DC ... 24 V AC/DC
---------------------	---------------------------

# LV- 12- 24UC - Plug-in module

2833712

<https://www.phoenixcontact.com/pc/products/2833712>



## Drawings

Circuit diagram

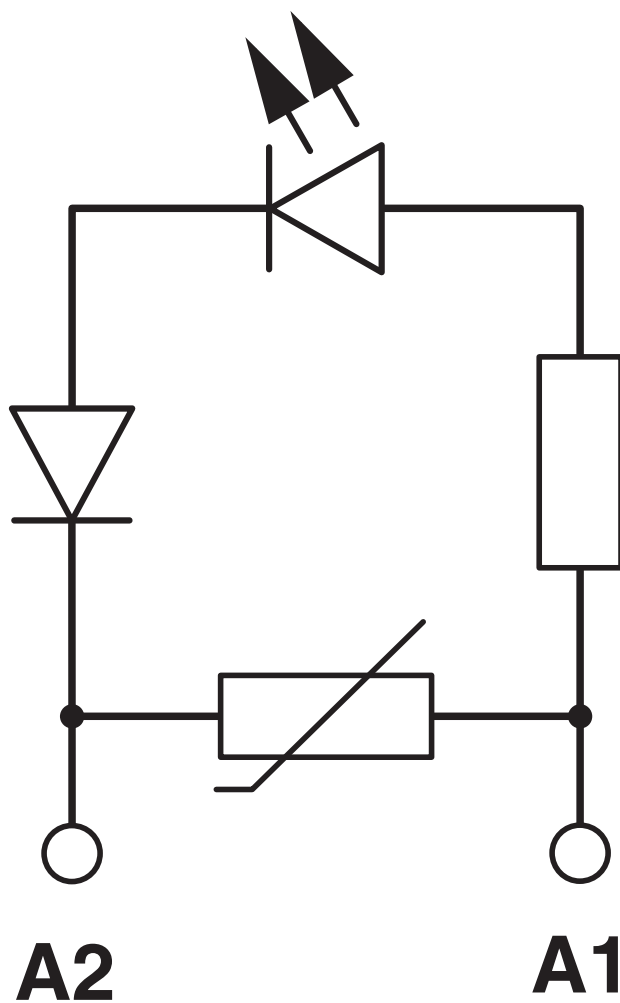

# LV- 12- 24UC - Plug-in module



2833712

<https://www.phoenixcontact.com/pc/products/2833712>

## Approvals

To download certificates, visit the product detail page: <https://www.phoenixcontact.com/pc/products/2833712>



**cUL Recognized**  
Approval ID: FILE E 140324



**UL Recognized**  
Approval ID: FILE E 140324



**EAC**  
Approval ID: RU C-DE.A\*30.B.01742

**cULus Recognized**

# LV- 12- 24UC - Plug-in module



2833712

<https://www.phoenixcontact.com/pc/products/2833712>

## Classifications

### ECLASS

ECLASS-11.0	27371692
ECLASS-12.0	27371692
ECLASS-13.0	27371692

### ETIM

ETIM 9.0	EC002586
----------	----------

### UNSPSC

UNSPSC 21.0	39122300
-------------	----------

# LV- 12- 24UC - Plug-in module

2833712

<https://www.phoenixcontact.com/pc/products/2833712>



## Environmental product compliance

China RoHS	Environmentally friendly use period: unlimited = EFUP-e No hazardous substances above threshold values
------------	---

Phoenix Contact 2024 © - all rights reserved  
<https://www.phoenixcontact.com>

PHOENIX CONTACT GmbH & Co. KG  
Flachmarktstraße 8  
D-32825 Blomberg  
+49 (0) 5235-3 00  
[info@phoenixcontact.com](mailto:info@phoenixcontact.com)