

SCT-D-SUB 15-KG - Housing

2749563

<https://www.phoenixcontact.com/pc/products/2749563>



Please be informed that the data shown in this PDF document is generated from our online catalog. Please find the complete data in the user documentation. Our general terms of use for downloads are valid.

Cable housing for D-SUB-15



Commercial data

Item number	2749563
Packing unit	1 pc
Minimum order quantity	1 pc
Product key	CL311Z
Catalog page	Page 214 (CC-2005)
GTIN	4017918104986
Weight per piece (including packing)	49 g
Weight per piece (excluding packing)	48.1 g
Customs tariff number	85389099
Country of origin	DK

SCT-D-SUB 15-KG - Housing

2749563

<https://www.phoenixcontact.com/pc/products/2749563>



Technical data

Product properties

Product type	Cable housing
Product family	DATATRAB

Material specifications

Color	Silver
Housing material	Zinc die-cast
Housing surface material	nickel-plated

SCT-D-SUB 15-KG - Housing

2749563

<https://www.phoenixcontact.com/pc/products/2749563>



Drawings

Dimensional drawing

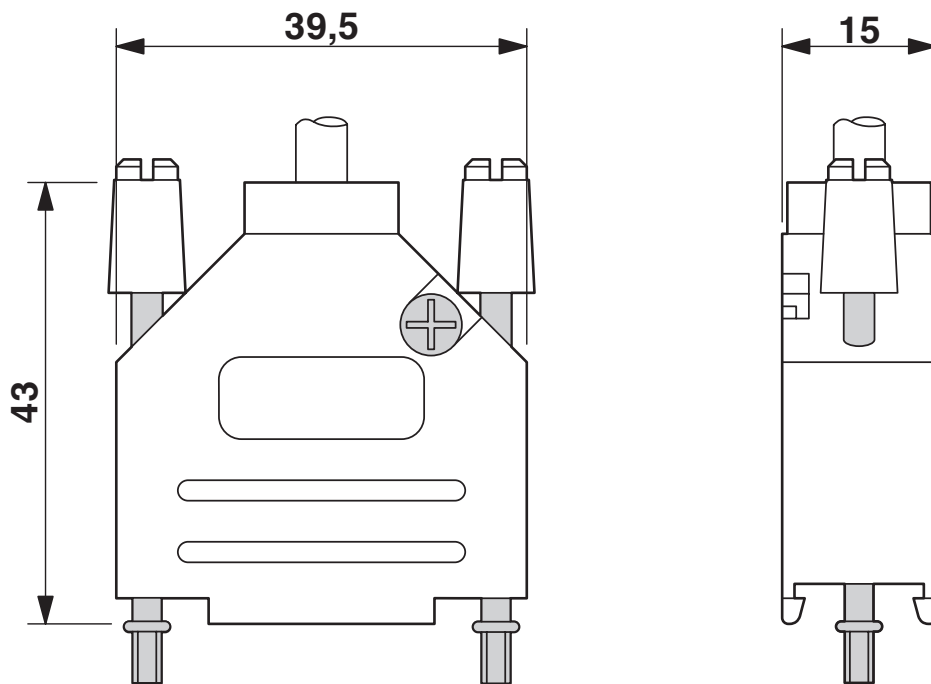

SCT-D-SUB 15-KG - Housing

2749563

<https://www.phoenixcontact.com/pc/products/2749563>



Approvals

To download certificates, visit the product detail page: <https://www.phoenixcontact.com/pc/products/2749563>



EAC

Approval ID: EAC-Zulassung

SCT-D-SUB 15-KG - Housing



2749563

<https://www.phoenixcontact.com/pc/products/2749563>

Classifications

ECLASS

ECLASS-11.0	27130890
ECLASS-13.0	27171503

ETIM

ETIM 9.0	EC001466
----------	----------

UNSPSC

UNSPSC 21.0	39121600
-------------	----------

SCT-D-SUB 15-KG - Housing

2749563

<https://www.phoenixcontact.com/pc/products/2749563>



Environmental product compliance

China RoHS	Environmentally friendly use period: unlimited = EFUP-e
	No hazardous substances above threshold values

Phoenix Contact 2024 © - all rights reserved
<https://www.phoenixcontact.com>

PHOENIX CONTACT GmbH & Co. KG
Flachmarktstraße 8
D-32825 Blomberg
+49 (0) 5235-3 00
info@phoenixcontact.com