

NEMA Motor Data



Ordering data : **1LE2221-4EB31-2AA3**

Client order no. :
Order no. :
Offer no. :
Remarks :

Item no. :
Consignment no. :
Project :

Nameplate Data	Mounting and motor protection
----------------	-------------------------------

Type	GP100 - NEMA Premium Efficiency		
HP	200.0	Rating	Cont.
Voltage	(12) 460V STD, 60Hz	Ins. Class	Class F (Standard)
Amps	228.0 A	S.F.	1.15
FL RPM	1785	Amb. Temp.	40 deg C
FL Efficiency	96.2 %	Temp. Rise	Class B
FRAME	B447T	kVA Code	G
DE AFBMA	90BC03JP30	NEMA Des	B
ODE AFBMA	80BC02JPP30	Mtr WT	2207.04
60 Hertz	3 Ph	TEFC	IP 54

Type of construction	(A) Foot mounted - End shield
Motor protection	(A) No winding protection
Terminal box design	(3) Mounting - F-1

Bearing Data		
--------------	--	--

	DE	ODE
Bearing Size	6318 Z C3 S0	6216 ZZ C3 S0
Bearing Type	Ball Bearing	Ball Bearing
AFBMA	90BC03JP30	80BC02JPP30

Typical Performance Data					
--------------------------	--	--	--	--	--

Load	No Load	1/2	3/4	Full Load	LRC
Efficiency		96.2 %	96.5 %	96.2 %	
Power Factor		75.0	83.0	85.0	
Current (A)	73.0 A	129.8 A	175.4 A	228.0 A	1450.0 A
Inverter Duty	VT	20:1	CT	4:1	

Mechanical Data				
-----------------	--	--	--	--

SAFE STALL TIME	HOT (s)	18	COLD (s)	25
Rtr wt (lbs)	569.39	Rtr WK2	56.4	
FLT (lb-ft)	588.000	LRT	160	BDT 200
Ext Load Inertia (WK2) Capability	105.0 lb-ft ²			

Typical Noise Data									
--------------------	--	--	--	--	--	--	--	--	--

A-weighted Sound	Octave Band Center Frequencies Hertz (Hz)								
Pressure Level	125	250	500	1000	2000	4000	8000	SPL	74
at 3 feet	51	63	70	67	68	60	50	SPwrL	85

Wiring Connection Information					
-------------------------------	--	--	--	--	--

Description	3 PHASE - 3 LEAD - DELTA				
Voltage	L1	L2	L3	Connected together	
-----	-----	-----	-----	-----	-
-----	T1	T2	T3	-----	Δ

Special design :

Lubrication Information	
-------------------------	--

Manufacturer	Mobil Polyrex EM or equal
Type	Polyurea (standard)
DE Capacity (oz.)	10.40
ODEnd Capacity (oz.)	7.50

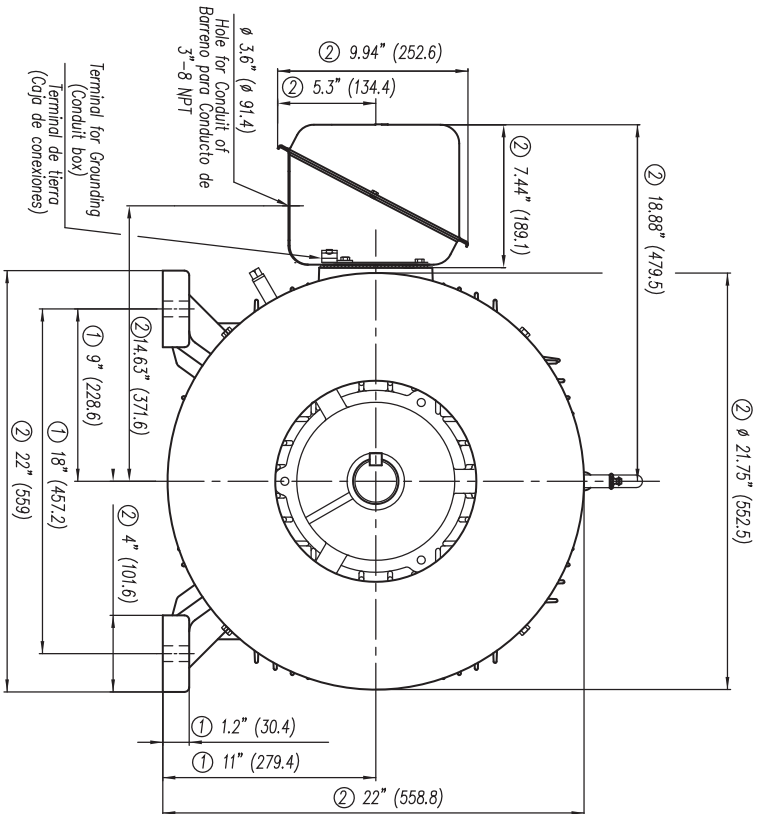

- ① Tolerances According to NEMA Std.
- ② All these dimensions corresponding to assemblies and castings shall have a tolerance as per DIN standard 1686-GTB-19
- ③ Not According to NEMA Std.

CERTIFIED PRINT / CERTIFICACION

CUSTOMER/CLIENTE		SALES/VENTAS	
PROJECT/OPERA		TYPE/USO	
SP	REV	FRAME/ARM	PHASES
			Hz

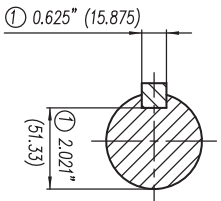
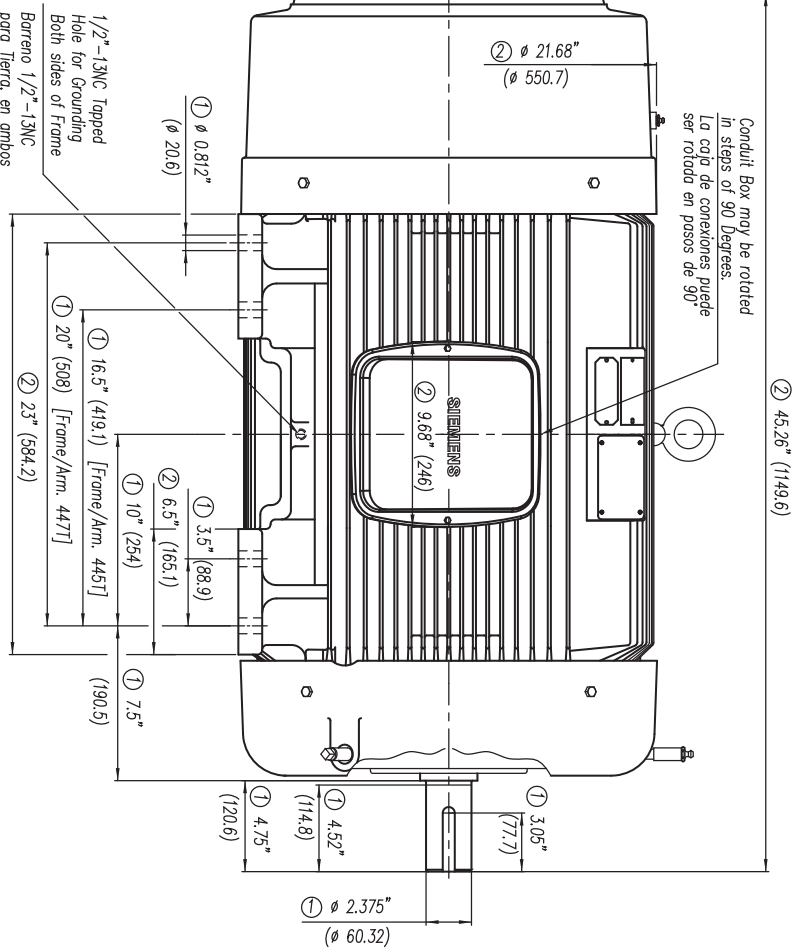

Keyseat detail
Detalle Cuñero

Tol. in mm. acc. to Tol. en mm. según DIN-1686-GTB-19	Over/desde for/hasta	18	± 4.5
		18	± 4.7
		30	± 5
		50	± 5.5
		80	± 6
		120	± 6.5
		180	± 7
		250	± 7.5
		315	± 8
		400	± 8.5
		500	± 9.5
		630	± 10

European Projection/Proyección Europea	Modific.
Dim. in inches/Dim. en pulg.	Date/Fecha
Drawn/Elab. 08/04/10	A. Perez
Check/Rev. 02/04/10	A. Red
Std Ckd/Aut.	

SIEMENS	Outline/Dimensiones
GUADALAJARA FACTORY	New NEMA Motors (TS) Short Shaft/ Espliga Corta
	Type/ Tipo: GP10 y GP100 445/447TS FRAME (Foot & mNP)
Ref. 3MSE 750 0645	3MSE 750 1510
Rep. 1580	Scale/ Escala: ---

SIEMENS INDUSTRY, INC.

HP 200 VOLTS < 600V RPM 1800 TYPE GP100
HZ 60 PHASE 3 FRAME B447T NEMA B

TORQUE & CURRENT VS. SPEED

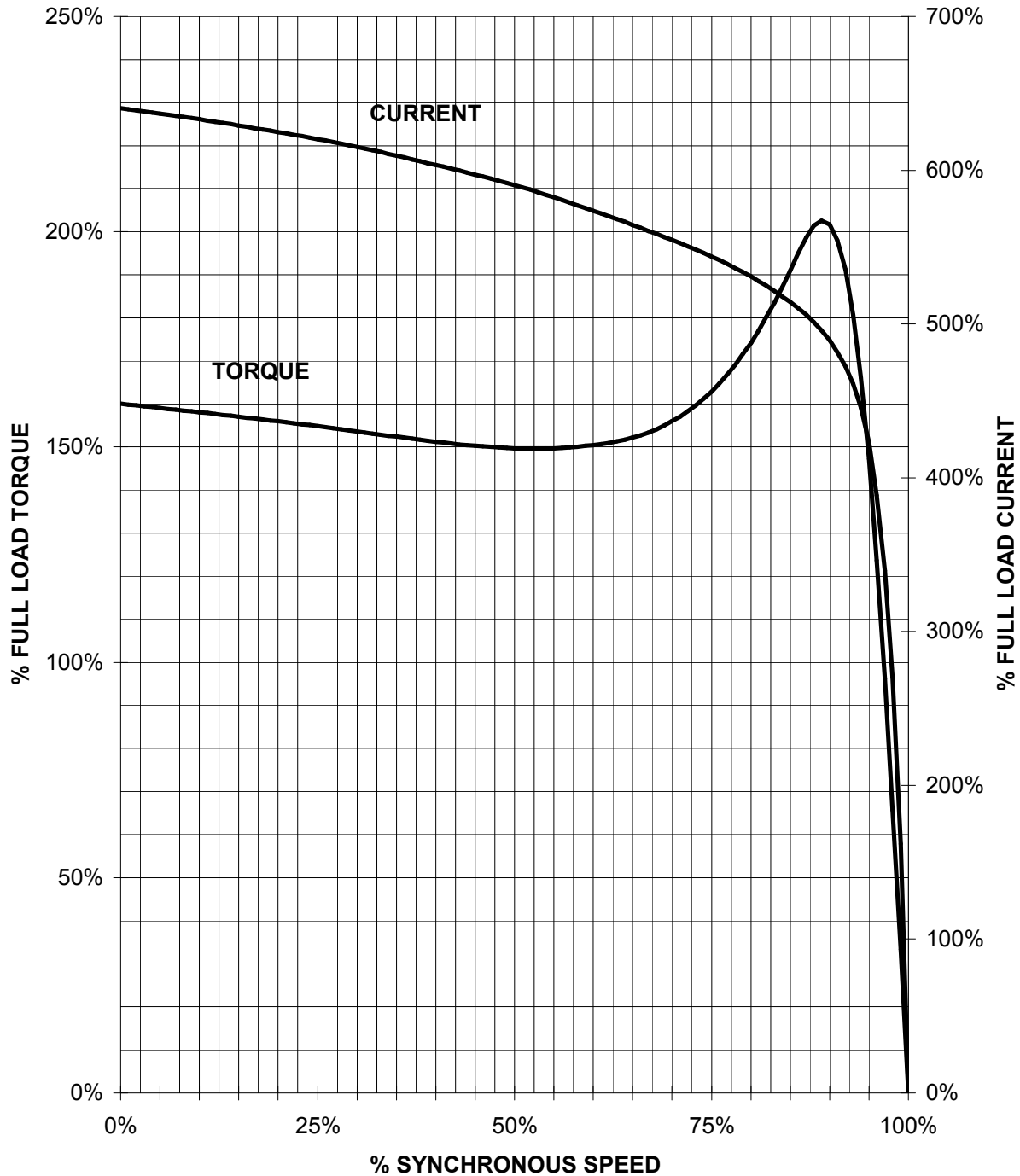

CUSTOMER: _____ ORDER#: _____

200 HP 1800 RPM B447T FRAME 460 VOLTS 3 PHASE NEMA DESIGN B

SIEMENS INDUSTRY, INC.
PERFORMANCE CURVE
GP100

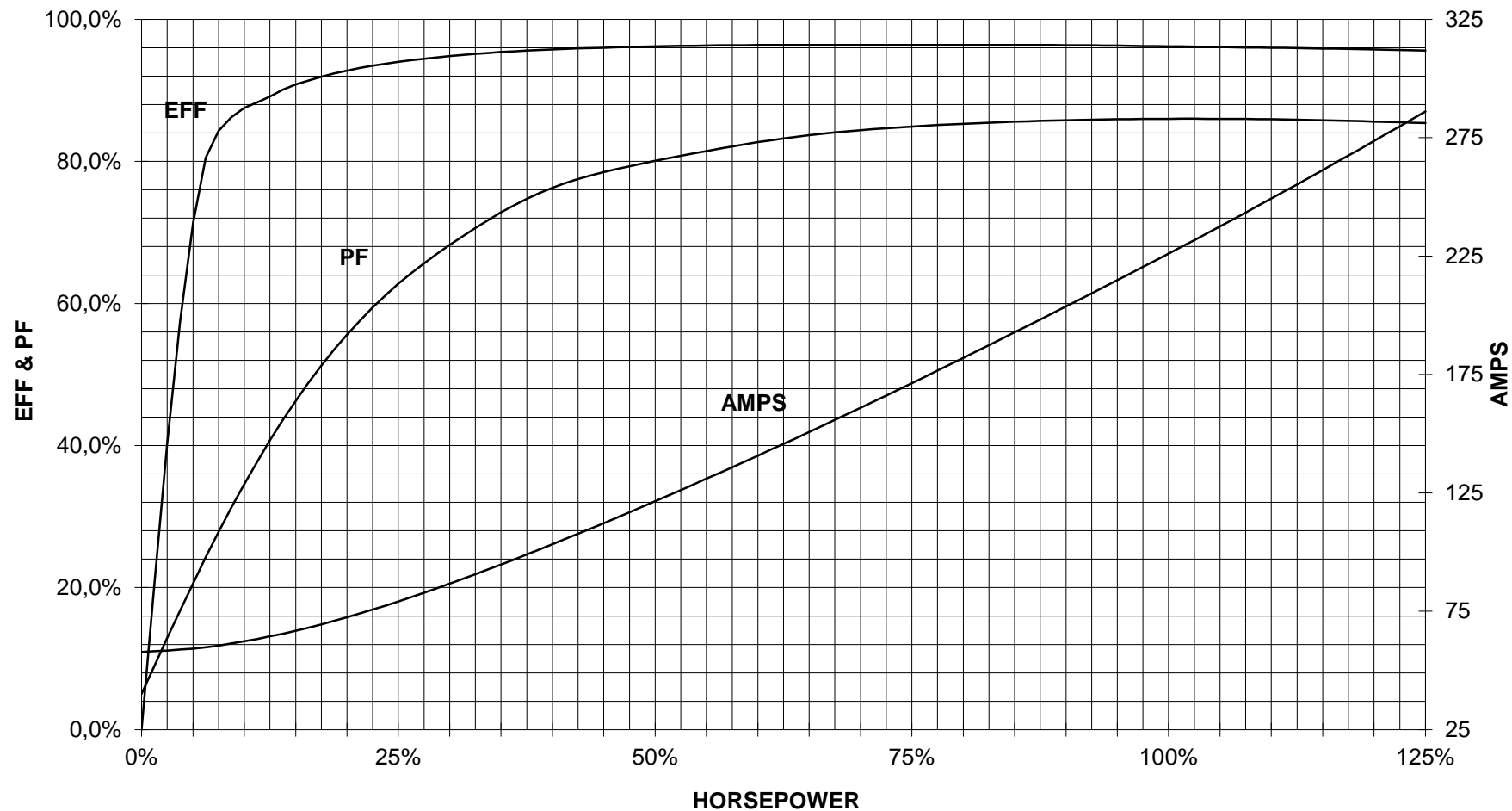

CUSTOMER: _____ ORDER #: _____

PERFORMANCE BASED ON DESIGN CALCULATIONS. SUBJECT TO CHANGE WITHOUT NOTICE.

REV. 1

2

1

3 PHASE - 3 LEADS - DELTA

L1	L2	L3	CONN.
T1	T2	T3	△

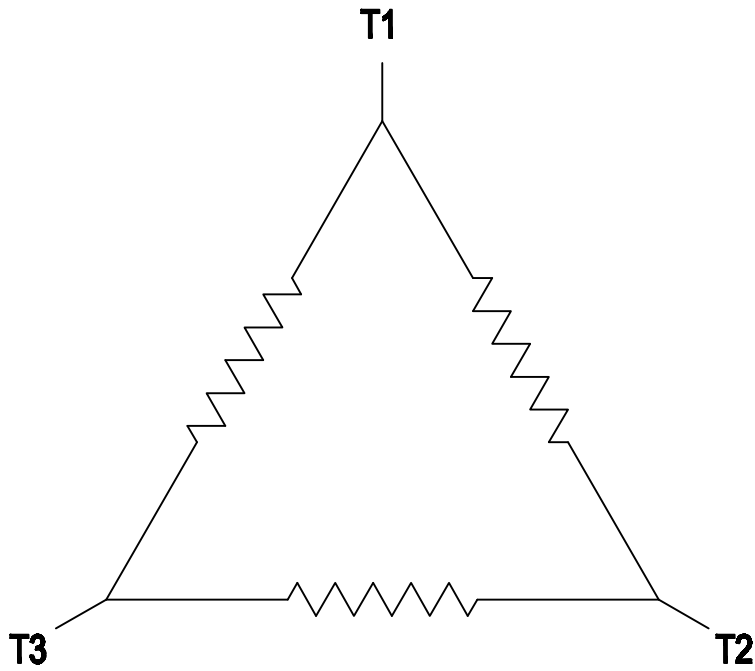

B

B

A

A

THIS IS A CAD DRAWING
DO NOT MAKE MANUAL CHANGES

01 | 09-27-07

TYPE

-CONFIDENTIAL-

PROPERTY OF

Siemens Energy & Automation, Inc.
Industrial Motor Division - Little Rock, AR

FRAME

HP

NAME

WIRING DIAGRAM

VOLTS

RPM

HZ

PH

3

Customer

PO #

SO #

DRAWN 9.24.07 DATE JRH

CHECKED DATE

APP DATE

SHEET

1 OF 1

Sim. To

PART NO.

51-382-114-504

A

2

1