

# VS-15-SD - D-SUB protective cover



1887099

<https://www.phoenixcontact.com/pc/products/1887099>

Please be informed that the data shown in this PDF document is generated from our online catalog. Please find the complete data in the user documentation. Our general terms of use for downloads are valid.

D-SUB protective cover, shell size 2, IP54 degree of protection, for panel mounting frame and sleeve housing VS-15-...



## Commercial data

Item number	1887099
Packing unit	5 pc
Minimum order quantity	1 pc
Product key	ABNCBZ
Catalog page	Page 219 (C-2-2013)
GTIN	4017918817473
Weight per piece (including packing)	8.01 g
Weight per piece (excluding packing)	7.87 g
Customs tariff number	85389099
Country of origin	DE

# VS-15-SD - D-SUB protective cover

1887099

<https://www.phoenixcontact.com/pc/products/1887099>

## Technical data

### Product properties

Product type	Protective cover
Type	15

### Dimensions

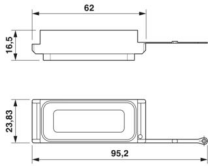
Dimensional drawing	
Width	16.5 mm
Height	23.8 mm
Length	95.9 mm

### Material specifications

Color	gray
Material	Plastic
Flammability rating according to UL 94	V0
Housing material	PA

### Mechanical properties

#### Mechanical data

Insertion/withdrawal cycles	≥ 1000
-----------------------------	--------

### Environmental and real-life conditions

#### Ambient conditions

Degree of protection	IP54
Ambient temperature (operation)	-40 °C ... 80 °C

# VS-15-SD - D-SUB protective cover

1887099

<https://www.phoenixcontact.com/pc/products/1887099>



## Drawings

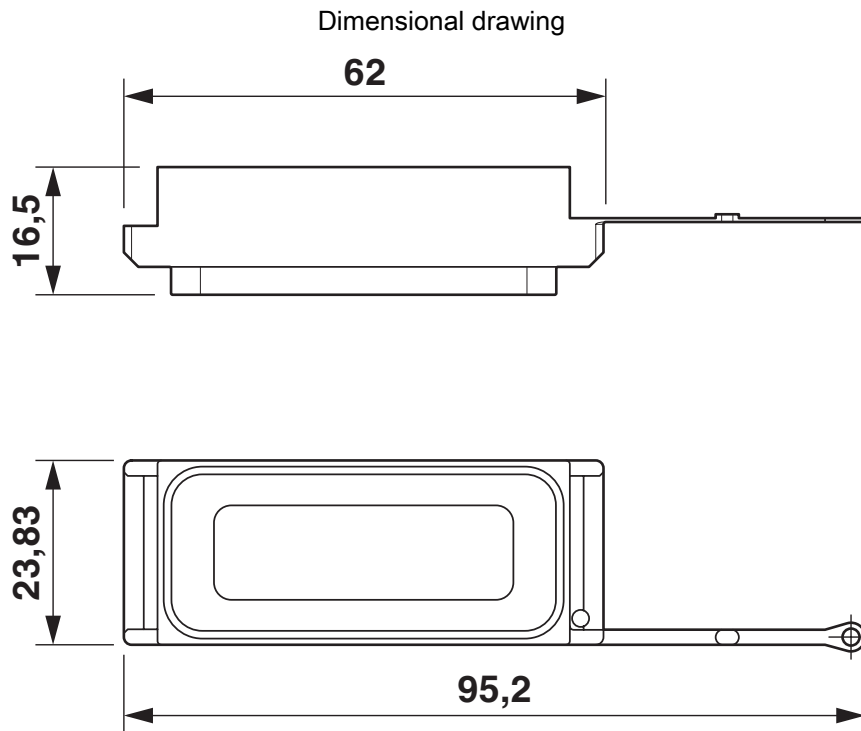

Protective cover for D-SUB

# VS-15-SD - D-SUB protective cover



1887099

<https://www.phoenixcontact.com/pc/products/1887099>

## Classifications

### ECLASS

ECLASS-11.0	27440208
ECLASS-12.0	27440208
ECLASS-13.0	27440208

### ETIM

ETIM 9.0	EC002314
----------	----------

### UNSPSC

UNSPSC 21.0	39121400
-------------	----------

# VS-15-SD - D-SUB protective cover



1887099

<https://www.phoenixcontact.com/pc/products/1887099>

## Environmental product compliance

China RoHS	Environmentally friendly use period: unlimited = EFUP-e
	No hazardous substances above threshold values

Phoenix Contact 2024 © - all rights reserved  
<https://www.phoenixcontact.com>

PHOENIX CONTACT GmbH & Co. KG  
Flachmarktstraße 8  
D-32825 Blomberg  
+49 (0) 5235-3 00  
[info@phoenixcontact.com](mailto:info@phoenixcontact.com)